

Unitech Centrifugal Pumps Series 160

Models PC160M1R

APPLICATION:

Pumps of this type transport food, aggressive and other fluids pure from mechanical alloys. Find application in all areas of food, chemical, pharmaceutical and others industries, which requires specific hydro- transport and exist similar conditions.

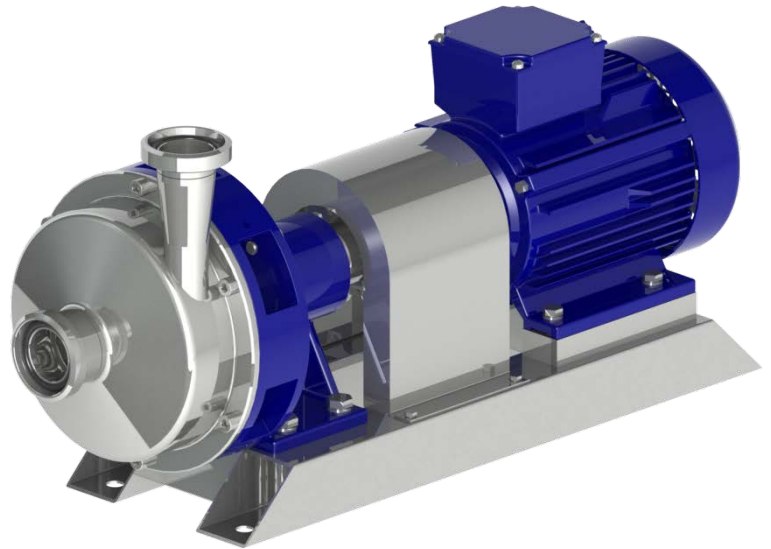

STANDARD EQUIPMENT:

Pump with own geared body joined to the standard electric motor through a connector
 Mounted on a frame.
 Material AISI 304
 Standard Inlet / Outlet: male union joints DIN 11851

OPTIONS:

***V-modification** (Double mechanical sealing)
***Ex-modification** (with explosion proof el. motor)
***K-modification** (mounted on a trolley with Starter)
***T-modification** (with double wall for cooling/heating)
 Material AISI 316
 Connection: Garolla, SMS, Macon, Clamp, etc.
***Other Options on Request**

Technical Parameters					
Model	Capacity	Head	Electric Motor	Connection	Temperature
PC160M1R	up to 20 m ³ /h	up to 3.0bar	up to 3.0kW	male union joints DIN 11851	+2 ÷ +120°C
PC161M1R	up to 100 m ³ /h	up to 5.0bar	up to 11.0kW		

Characteristic Curves of the Unitech Centrifugal Pumps Series 160

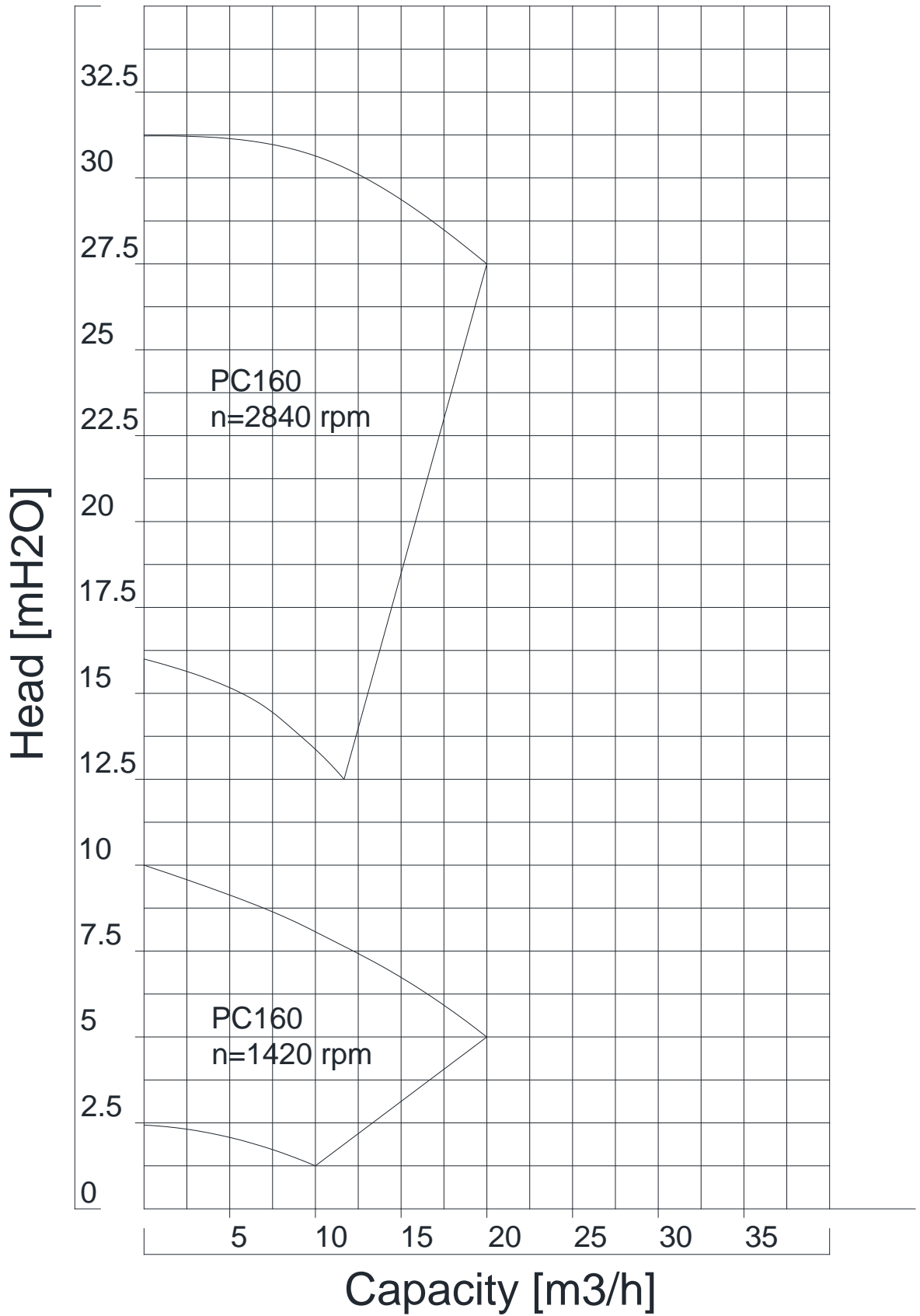

*with fluid – water at temperature 20 °C.
 *with pipes equal with pump's connections.

Characteristic Curves of the Unitech Centrifugal Pumps Series 161

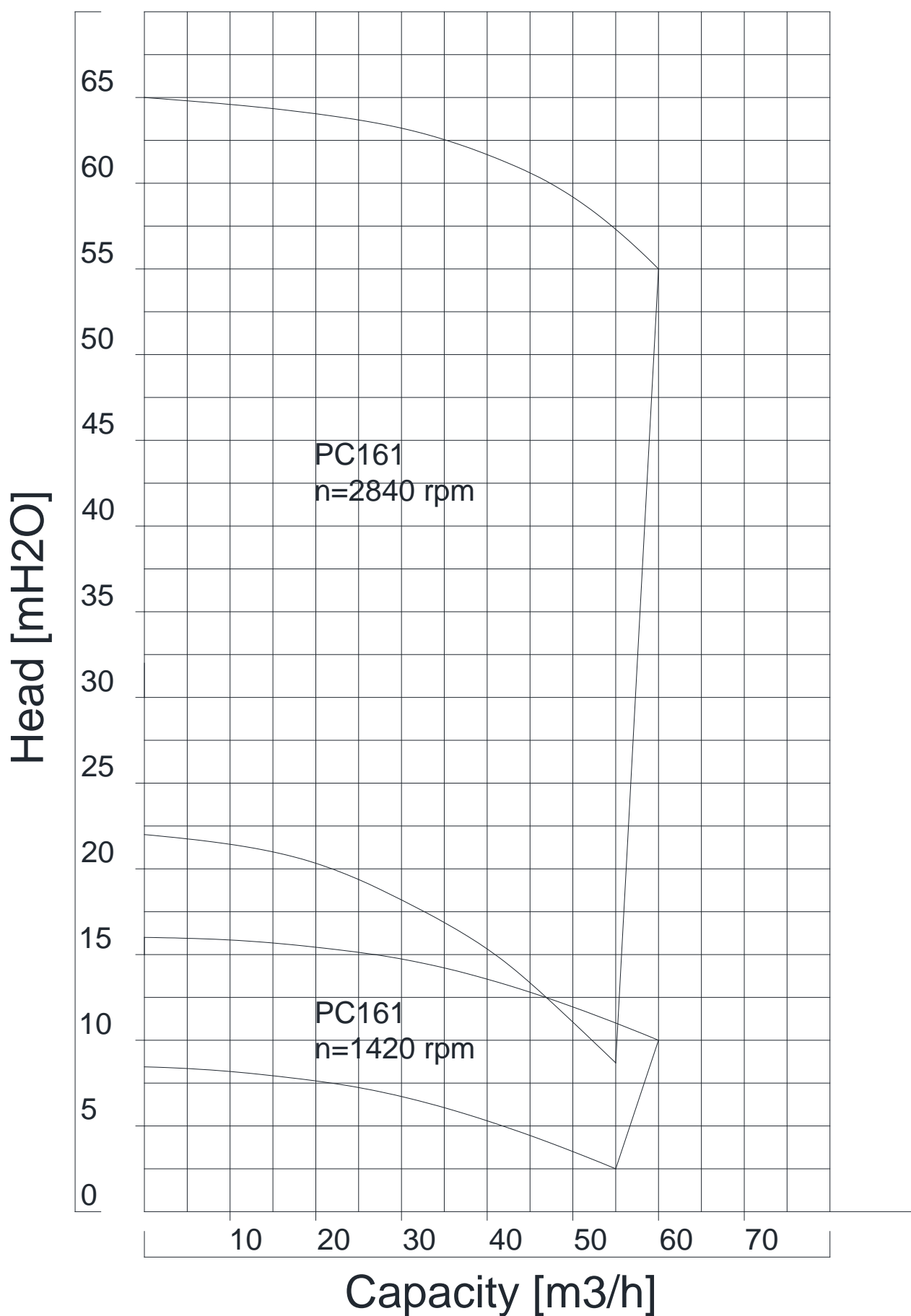

*with fluid – water at temperature 20 °C.
 *with pipes equal with pump's connections.

Dimensions of the Centrifugal Pumps Series 160

Models PC160M1R

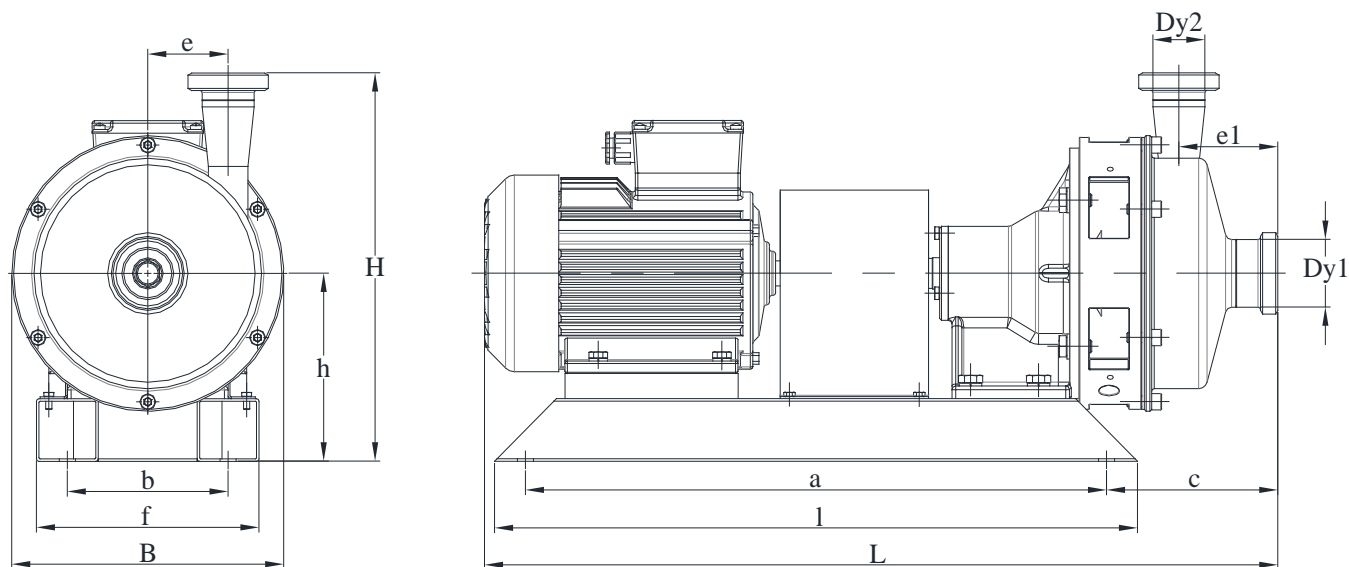

Dimensions, mm														
Model	Dy1	Dy2	L	B	H	h	e	e1	c	a	b	l	f	s
PC160M1R – 0.75/4	40 50	32 40 50	640	220	310	150	65	81	140	470	130	520	180	13
PC160M1R – 0.75/2														
PC160M1R – 1.1/2														
PC160M1R – 1.5/2			665							510		560		
PC160M1R – 2.2/2														
PC160M1R – 3.0/2			690											
PC161M1R – 2.2/4	50 65 80	50 65 80	860	310	385	165	95	111	215	585	210	630	270	13
PC161M1R – 3.0/2														
PC161M1R – 3.0/4														
PC161M1R – 4.0/2			870							670		710		
PC161M1R – 5.5/2														
PC161M1R – 7.5/2			900											
PC161M1R – 11.0/2			940											

6600 Kardzhali, Bulgaria
 East Industrial Zone
 Post box 187
 Tel: +35936166650
 Fax: +35936166651
 E-mail: unitech@unitech.bg
 Web: www.unitech.bg